

## Customer Information

Name

Company

Address

State/Prov.

Zip/PC

Tel.

Fax

email

End User

Cell / Operation #

Weld Type  Spot  
 Projection (see Nut Application Sheet)

Application Type  Pedestal  Portable  Non-Equalizing  
 Fixture  Equalizing  Robot

## Gun Details

### Robot Mount:

Top (above actuator)  
 LH (left side of transformer)  
 RH (right side of transformer)  
 Bottom (below transformer)  
 Rear (off back of transformer)

### Electrode Details:

Male  
 Female

### Nose Type:

A  
 B  
 Other:

### Robot Pattern/Type:

## Transformer

AC  
 MFDC

### Actuator

Servo Motor #   
 Air/Oil  
 Air

Voltage:

## Metal Specs/Type

Material Thickness/Stackups & Type

## Water Hose Colour

Water In:   
 Water Out:

**NOTE: All FlexGun™ weld guns come hoses to water manifold with polyurethane tubing and push to lock fittings, unless otherwise specified**

## Duty Cycle

welds/min.

CenterLine recommends max. 2.5 sec. between welds.

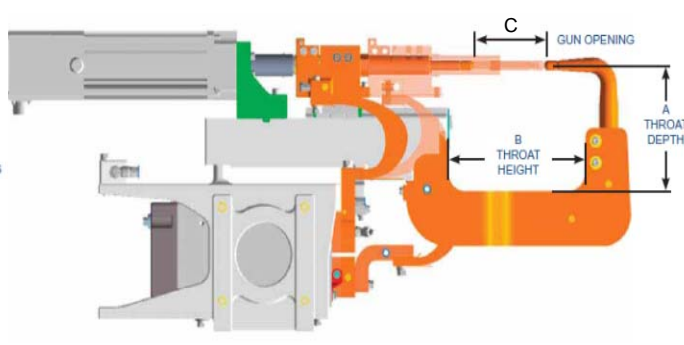
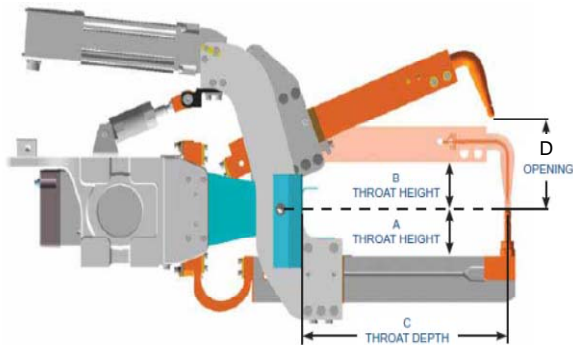

A

B

C

D

A

B

C